Embedding Landscape Neutrality to Build a *Bridge* from the Conventional to a More Efficient Three-bit Multiplier Circuit

Vesselin K. Vassilev
School of Computing
Napier University
Edinburgh, EH14 1DJ, Scotland
Tel: ++44(0)131-455 4432
E-mail: v.vassilev@dcs.napier.ac.uk

A genotype-phenotype mapping has been devised to allow digital circuits to be evolved on an array of logic cells. The resulting fitness landscapes are characterised with *neutral networks* that are connected sub-graphs of genotypes with equal fitness values. The paper shows that landscape neutrality embedded by the genotype-phenotype mapping is beneficial for the evolutionary design of digital circuits and particularly the three-bit multiplier circuit. This is further used in the *design* of a neutral network that connects the conventional with other more efficient designs. The paper shows that very efficient digital circuits can be obtained from the conventional by building a “neutral bridge” between the conventional and the unconventional designs (Figure 1). Thus a three-bit multiplier

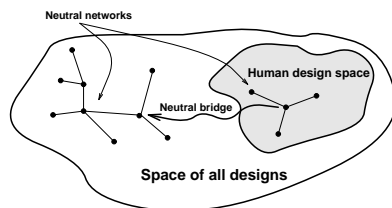

Figure 1: The “neutral bridge” between the human design space and the evolved more efficient digital circuits in the space of all designs.

was evolved that is 23% more efficient (in terms of number of two-input gates used) than the most efficient known conventional design (Figure 2). This is the **most efficient design** ever produced and it is shown for a first time here.

Efficient three-bit multiplier circuits can also be evolved from scratch. A disadvantage of such an approach however is that the evolution may end up with a functionally incorrect evolved circuit. This may be a problem if circuit evolution is implemented on hardware and a functionally correct circuit is required in real time. The approach described here gives a pos-

Julian F. Miller
School of Computer Science
University of Birmingham
Birmingham, B15 2TT, England
Tel: ++44(0)121-414 3710
E-mail: j.miller@cs.bham.ac.uk

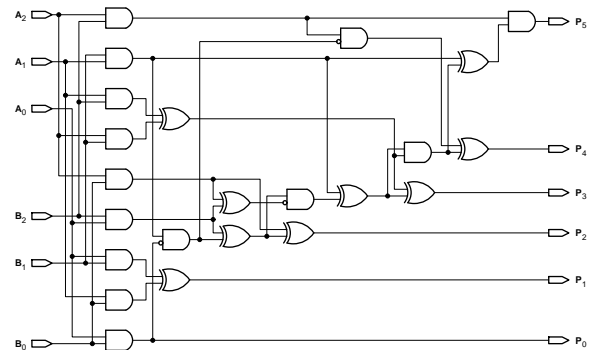

Figure 2: The three-bit multiplier circuit evolved from the conventional solution. The circuit consists of 23 two-input gates.

sible alternative. It suggests that an efficient solution may be attained in a much more *reliable* way.

An electronic circuit can be designed by using smaller circuits as building blocks. The electronic circuits are modular in construction and this is cleverly used in the conventional design to construct bigger circuits from many building blocks also known as modules. Unfortunately modules for assembling circuits that have the “nice” features of the evolved designs have not yet been inferred (Miller *et al.*, 2000). The approach described here together with the principles of the conventional design defines a new method of building efficient circuits without expert recommendations. Perhaps this is a step towards the automatic design of more efficient circuits.

References

- Miller, J. F., Job, D. and Vassilev, V. K. (2000). Principles in the evolutionary design of digital circuits. *Journal of Genetic Programming and Evolvable Machines* 1 (1/2,3). In press.